

# Oryx

## *Hardware Manual*

Description and Configuration

Revision 3.2, March 2003

Compiled by Patrick Shaw Stewart and Peter Baldock

Copyright 1991-2002, Douglas Instruments Ltd.

Douglas Instruments Limited

Douglas House ♦ East Garston ♦ Hungerford ♦ Berkshire, RG17 7HD ♦ UK

<http://www.douglasinstruments.com>

## **NOTE TO ALL USERS:**

Some of the Oryx Systems are now fitted with belt-drives for the X-Y axes on the XYZV Plateloader. This replaces the leadscrew system described later in this manual.

All other information remains the same.

# CONTENTS

<b>SETTING UP THE SYSTEM</b>	<b>4</b>
Software Installation .....	4
Lay-out of the Hardware .....	4
Recording the Positions of Motors .....	5
Unpacking.....	5
Electrical Connection .....	5
Rezeroing Motorized Syringe Drivers.....	5
Mounting 100 µl Gas-Tight Syringes on Motorized Syringe Drivers, and Filling them with Water .....	6
Installing 10 ml syringe.....	8
Replacing shafts on the Y-Axis of the Plate Loader .....	8
Installing Lead-screws on the Plate Loader.....	9
Installing the Z and V Arms.....	10
Installing the Y Hanger, and Testing the Performance of the Plateloader .....	11
Rezeroing all Motors of the Plate Loader.....	12
Adjusting the Alignment of the Plate Loader using Software .....	12
<b>USE AND MAINTENANCE OF THE HARDWARE</b>	<b>13</b>
Installing Microtips .....	13
Use of Liquid Handling System Including Valve Positions .....	13
Refilling 100µl Gas-Tight Syringes with Water .....	13
Debubbling .....	13
Flushing Tubing between Valves.....	14
Filling Microtip with Solution .....	14
Dispensing Experiments.....	15
Flushing Microtip after Use .....	15
Protein Coatings of Microtip.....	15
Blockages.....	15
Unblocking Microtips .....	15
Chemical Inertness .....	16
Tubing Connections .....	16
Lubrication of Syringe Drivers and Plate Loader.....	17
Lubrication of Shafts.....	17
Lead-screws .....	17
Spillages.....	17
XYZV Plate Loader .....	17
Jamming.....	17
Adjustment of XYZV Plate Loader .....	17
<b>HARDWARE CONFIGURATION AND CONTROL</b>	<b>18</b>
Using Different Syringes with the System .....	18
Changing Plates.....	18
WASP and ASPRUN .....	18
Pick And Mix .....	18
XSTEP – Changing Plates .....	18
Adding Further Plates to PLATES.DAT .....	18
Hardware Configuration Files.....	19
HARDWARE.CFG.....	19
HARDWARE.FTH .....	19
Specifications .....	20
<b>INDEX OF MANUAL</b>	<b>21</b>

## SETTING UP THE SYSTEM

### Software Installation

Follow the instructions on the separate sheet entitled “Installation Instructions for Crystallization Software Kit for IMPAX 1-5 and Oryx 6” to install the crystallization software. This sheet can be downloaded from the website, and a copy can be found at the back of the bound version.

### Lay-out of the Hardware

The layout of Oryx 6 is shown in the figure below. The system is driven by a PC, which is connected to the MCC Motion Control Center. The motorized syringes and the XYZV Plate Loader are in turn driven by the MCC using stepper motors. The MCC is a computer that generates the steps for the stepper motors, logs their positions etc. It runs under DOS, and it has either 2 or 3 DB5 stepper motor driver cards.

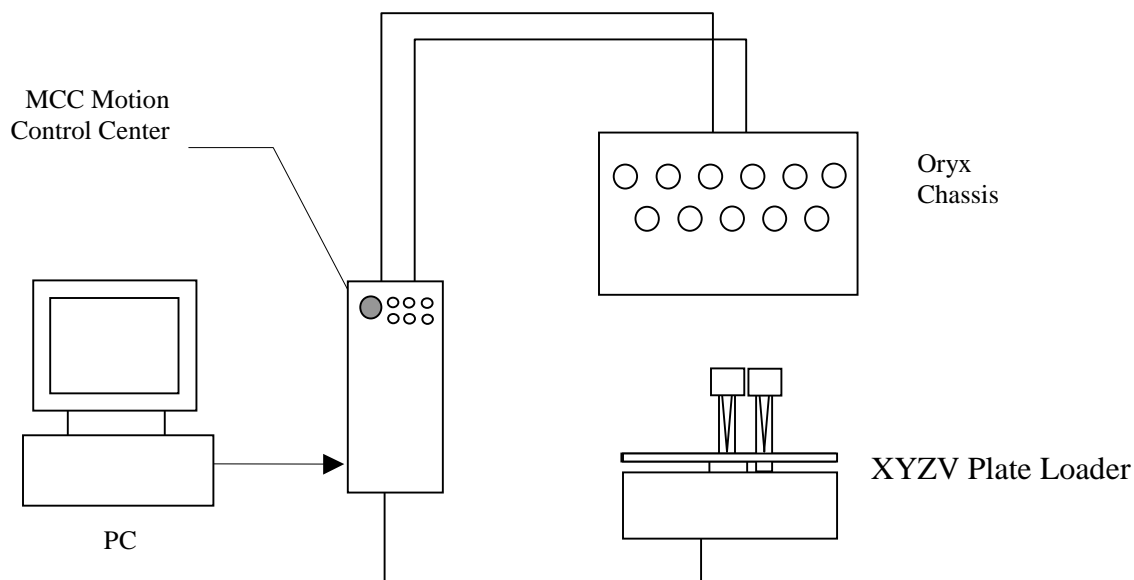

## Recording the Positions of Motors

When the system is first set up, the motors must be rezeroed using the *Front Panel* program, as described below.

After this, the software will automatically log the positions of all of the motors in the system and it will save these positions to disk at the end of each run. This means that it is not necessary to rezero the motors each time the computer is switched on. Only rezero if you have some reason to believe that the system may be incorrectly positioned. However, you must not switch off the computer without quitting all crystallization software. If you do this, you will be forced to rezero the next time that you use the system.

## Unpacking

Take the Chassis, MCC Motion Control Center, and the XYZV Plate Loader out of their packaging. Remove the tape from the Luer females on the Chassis. Remove the padding on the shafts of the Plate Loader. Unwrap the lead-screws and the Z- and V-arms. Take the motorized syringes and ground-glass syringes out of their packaging.

## Electrical Connection

1. All cables are individually labeled. Use the **long 9-way D-type cable** to connect the port labeled “serial port” on the MCC to the serial port of the computer.
2. Follow the labeling to connect MCC to the Chassis and Plate Loader using the three **37-way D-type cable**

The MCC also possesses outputs for a screen and keyboard. These can be used to diagnose malfunctions.

## Rezeroing Motorized Syringe Drivers

1. Switch on the MCC. Wait for around 30s to allow it to fully boot up. Switch on the host PC, and allow it to boot up.
2. On the PC, click on the start button, then *Program Files | Douglas Instruments | Front Panel*. Allow *Front Panel* to load.
3. Click on *Syringes | Rezero*.
4. Make sure that the check boxes are checked for all of the syringes, and click on *continue*.
5. If the 100  $\mu$ l syringes are already installed, turn the top row of valves as indicated. Click *Rezero*
6. Wait for around 30 seconds while the syringe drivers move to their lowest positions.

The motorized syringe drivers should now be in their **lowest** positions. When they reach the end of their travel, the syringe drives will miss steps and make a rattling noise. This will not harm the syringe drivers in any way. When you are sure that all of the syringe drives have reached their lowest positions, you can save time by clicking on the large red *stop button* to end the procedure.

## Mounting 100 ml Gas-Tight Syringes on Motorized Syringe Drivers, and Filling them with Water

1. Prepare about 250 ml of degassed pure water. This will prevent bubbles forming, and is essential for accurate dispensing.
2. Rezero syringe drives as described above.
3. Place a Hamilton Gas-Tight syringe in position on the first motorized syringe driver. Loosely clamp the barrel with the **barrel clamp**. Push the plunger down into the stainless **button clamp**, and lock the plunger in place by doing up the grub-screw.

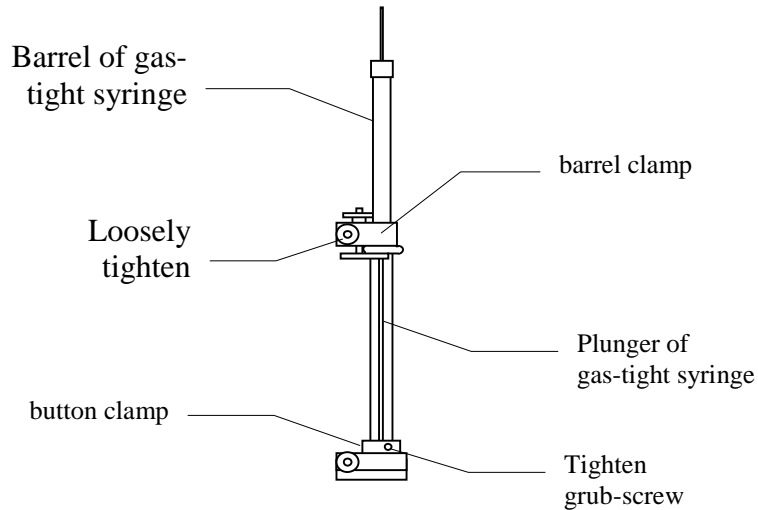

4. Connect the needle of the gas-tight syringe to the upper valve by pressing the connecting tubing onto it as far as the gripper fitting.
5. Fill a ground-glass syringe with degassed pure water and place it in the female luer connection on the upper valve.

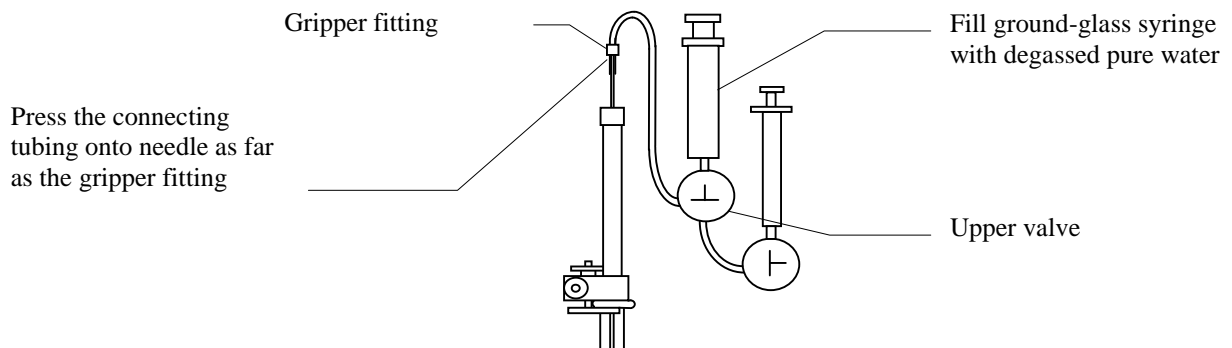

6. Release the barrel clamp, and remove the barrel of the gas-tight syringe, leaving the plunger in position.

7. Place the barrel over a waste container, and flush all air and bubbles out of the connecting tubing and gas-tight syringe. To ensure that no bubbles are left in the upper valve, tap the plunger of the ground glass syringe a few times. Flush away any bubbles that appear into the waste container.

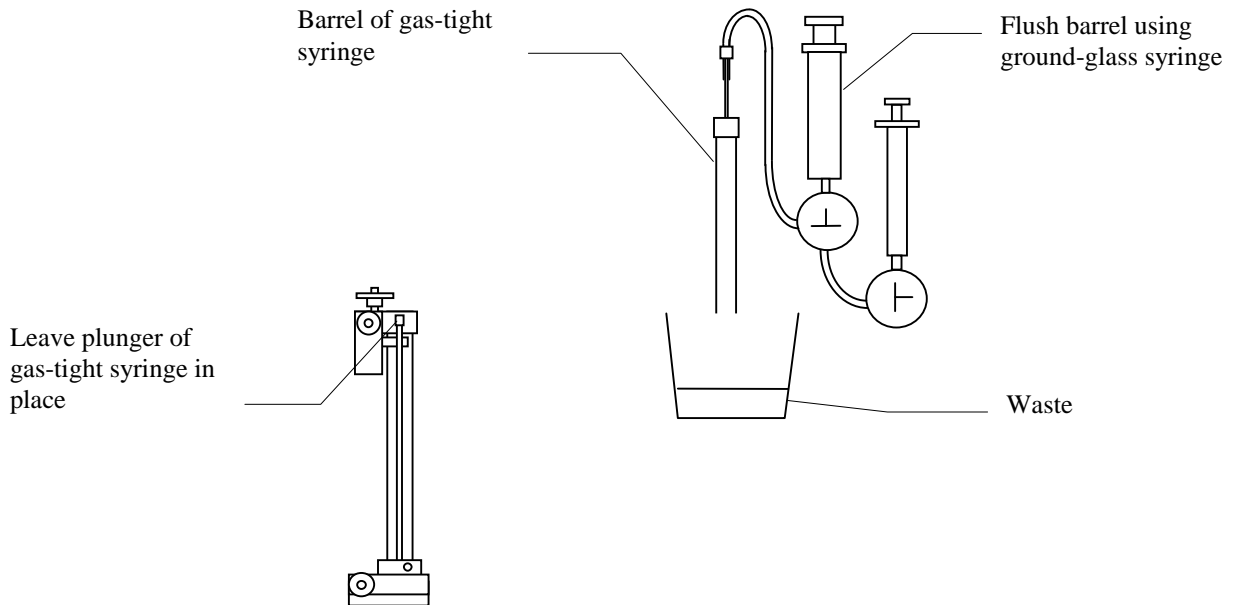

8. Mount the gas-tight syringe onto the motorized syringe driver as follows:
  - a. Slacken the flange clamp – labeled below
  - b. Feed the plunger back into the syringe barrel
  - c. Place the barrel into the V on the top of the syringe driver nose, *ensuring that the flange of the syringe barrel is between the nose and the flange clamp*
  - d. Tighten the barrel clamp
  - e. Tighten the flange clamp. The flange clamp and the barrel clamp should be done up finger-tight only.

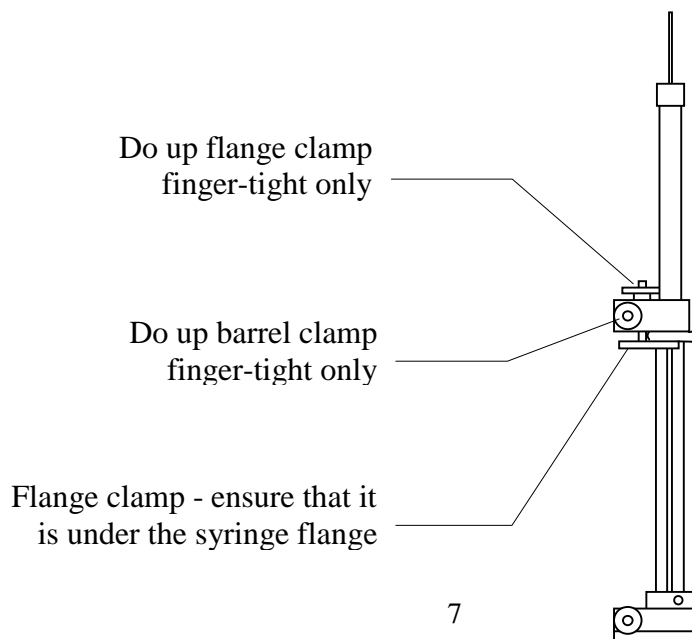

9. Turn the upper valve to the flush position (┆), and the lower valve to the dispense position (⌊). Place a waste beaker under the lower valve. Flush air and bubbles out of the connecting tubing between the upper and lower valves.
10. Repeat steps 1-8 for the remaining four channels.

## Installing 10 ml syringe

Undo the two clamps on the sixth syringe driver and install the 10ml syringe. Do up the two thumbscrews tightly. Connect the corresponding end-fitting to the sixth valve.

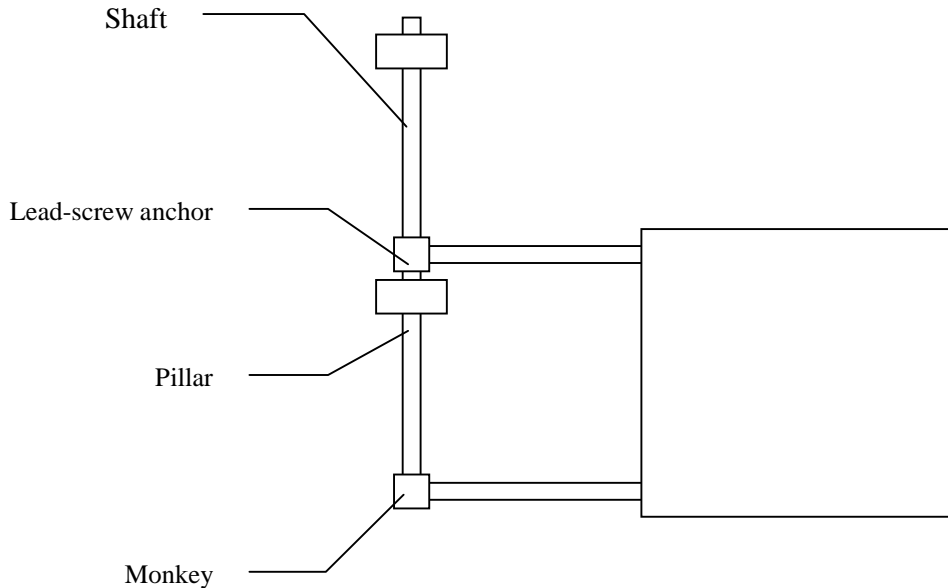

## Replacing shafts on the Y-Axis of the Plate Loader

The two short shafts of the Y-axis must be replaced with the two long shafts. The longest (455 mm) shaft goes on the right, and the slightly shorter (400 mm) shaft goes on the left.

1. Use a hex key to undo the screw that secures the plastic energy chain to the “monkey” at the front left corner of the Plate Loader.
2. Remove the screw from the threaded hole, keeping the screw in the energy chain. There is a grubscrew in the bottom of this threaded hole. Loosen it. Also loosen the corresponding grubscrew securing the shaft in the left (rear) lead-screw anchor.
3. Slide the left short shaft backwards, and, at the same time, slide in one of the longer shafts from the front, making sure that the table is supported all the time.
4. Tighten the grubscrew securing the 400 mm shaft to the lead screw anchor. Tighten the second grubscrew at the front left of the plateloader.
5. Similarly, install the longer 455 mm shaft on the right side.

6. Now ensure that the spacing of the monkeys and lead-screw anchors is correct. Push the table fully to the front. The spacing between the pillar and the front monkey should be 154 mm on both sides.
7. Test the Plate Loader to ensure that it moves freely, including its extreme positions.

**NOTE TO ALL USERS:**

Some of the Oryx Systems are now fitted with belt-drives for the X-Y axes on the XYZV Plateloader. This replaces the leadscrew system described next in this manual.

All other information remains the same.

## Installing Lead-screws on the Plate Loader

First, ensure the motors of the Plate Loader are in the phase 0 as follows:

1. Switch on the MCC. Wait for around 30s to allow it to boot up fully. Switch on the host PC, and allow it to boot up.
2. On the PC, click on the start button, then *Program Files | Douglas Instruments | Front Panel*. Allow *Front Panel* to load.
3. Click on *MCC | Rezero all motors*
4. Click on *Skip* to avoid rezeroing the syringes
5. Click on *Rezero* to rezero the motors of the vertical axes. Immediately click on the red Stop Button on the screen, or press the real stop button on the front of the MCC.
6. Click on *Rezero* to rezero the motor of the X-axis. Immediately click on or press the red Stop Button.
7. Click on *Rezero* to rezero the motor of the Y-axis. Immediately click on or press the red Stop Button.

(This procedure is similar to the regular rezeroing of the Plate Loader – see below - but nothing will move since the lead-screws are not yet installed or tightened.)

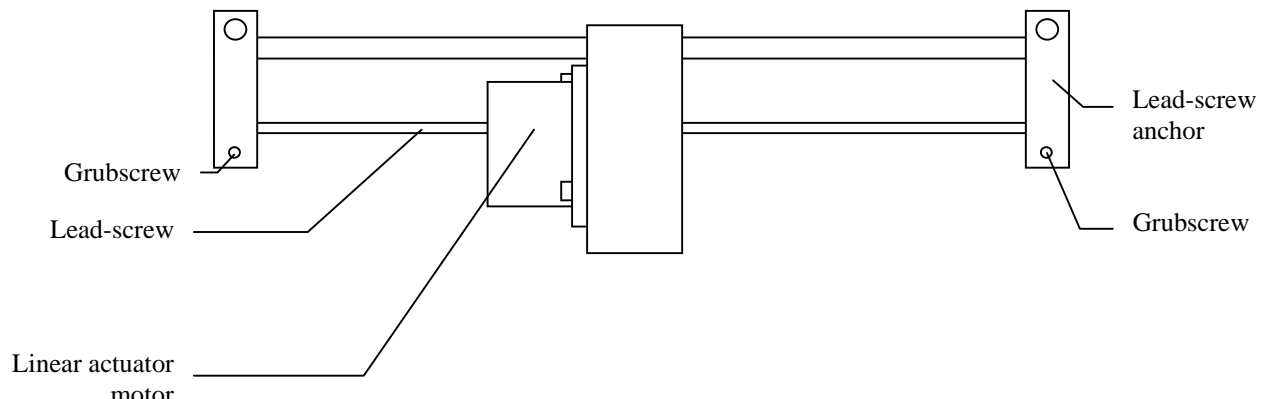

Now insert and “phase” the X lead-screw as follows:

1. Push the table of the Plate Loader to its extreme left-hand position. Now pull it as far as possible forwards.
2. Hold the longer lead-screw with the end with the groove to the left. Thread the lead-screw through linear actuator stepper motor on the X-axis of the Plate Loader. The end of the lead-screw with the groove should end up on the left – the “motor” end.
3. Move the table a few mms away from its extreme left-hand position. Now move it back to its extreme left-hand position by twisting the lead-screw with your fingers until it makes contact with its stop. Without allowing the lead-screw to move, do up the grubscrew on the “lead-screw anchor” that fixes the lead-screw.
4. Do up the grubscrew on the hanger that fixes the other end of the lead-screw.

This procedure ensures that the lead-screw is fixed in a predetermined position with respect to the motor. Such phasing is necessary for accurate reproducible positioning of the Plate Loader. Similarly, phase the Y-axis lead-screw as follows:

1. Push the table of the Plate Loader to its extreme back position.
2. Thread the shorter lead-screw through linear actuator stepper motor on the Y-axis of the Plate Loader. You will have to remove the Y “hanger” to do this. The end of the lead-screw with the groove should end up at the front – again this is the “motor” end.
3. Move the table (and shafts) a few mms away from its extreme back position. Now move it back to its extreme back position by twisting the lead-screw with your fingers until the lead-screw anchor makes contact with its stop. Without allowing the lead-screw to move, do up the grubscrew on the “lead-screw anchor” that fixes the lead-screw.
4. Replace the Y hanger, and loosely tighten its grubscrews.

## **Installing the Z and V Arms**

Now install the Z-arm and phase its lead-screw as follows:

1. Unwrap the Z-arm.
2. Remove the cardboard or plastic protective sleeving from around the Z lead-screw.
3. Twist the Z lead-screw with your fingers anticlockwise until it cannot rotate any further.
4. Insert the Z-arm.
5. Keeping the lead-screw fully rotated counterclockwise, do up the grub screw on the side of the arm to lock the lead-screw. Do not over-tighten this grub screw because there is a danger of stripping the thread.
6. Repeat steps 1 – 5 to install the V-arm.

## Installing the Y Hanger, and Testing the Performance of the Plateloader

1. Start *Front Panel*
2. Click *view / debug*
3. Click *Plate Loader / Test Axis*
4. Set *Axis* to *Y*, *Speed factor* to 1.4, *Amplitude (mm)* to 10, *Oscillations* to 10, *Places to test* to 1, and *Starting at* to 135. Click *Test*.
5. While the table is moving, gradually tighten the grubscrew that secures the lead-screw to the hanger. This grubscrew should be gradually tightened over several motor cycles.
6. When the table stops moving, click start again. While the table is moving, gradually tighten the top grubscrew, which secures the hanger to the Y shaft, again over several motor cycles.
7. If the Plate Loader misses steps (i.e. loses its position), slacken both grubscrews and repeat steps 4 – 6. Repeat up to 5 times if necessary, until the Plate Loader moves without missing steps.
8. If the Plate Loader still misses steps, inform Douglas Instruments of the problem. Then reduce the *Speed factor* to 1.2 and repeat steps 4 – 6 (again, try five times). If this fails, continue reducing the speed.
9. Follow a similar procedure for the X Z and V axes. If the Plate Loader misses steps, reduce the speed.

If it has proved necessary to reduce the *speed factor* of any axis below 1.4, the speed set in the configuration files should be changed as follows:

1. Edit the files *Global Data / HARDWARE.CFG*, and *MCC / HARDWARE.FTH*. Adjust the speed to for the axis in question.

$$\text{New speed} = (\text{original speed}) * (\text{successful speed factor}) / 1.4$$

2. Download *HARDWARE.FTH* to the MCC:
  - a) Click on *MCC Terminal* to move the focus to this window.
  - b) Click on *File / Upgrade Flash Firmware*
  - c) Click on *Open*, to open the file *Upgrade.UGL*
  - d) On the list of files that appears, click on *HARDWARE.FTH*
  - e) Click on *Upgrade Now*
  - f) Wait until the MCC stops flashing , which indicates that the file has been transferred.
  - g) Switch the MCC off and on, and wait until it reboots.
  - h) Close, then reopen *Front Panel*

If the Plate Loader has to be substantially slowed up, it will be necessary to visit the laboratory again to identify and solve the problem. The problem has probably been caused by damage to the Plate Loader

during transportation. Sometimes loosening the X or Y motor and adjusting its position can cure the problem. The Y motor may need to be adjusted up or down, and the X motor may need to be adjusted up, down or from side to side.

## Rezeroing all Motors of the Plate Loader

1. Switch on PC and MCC, and start the program *Front Panel* as described above.
2. Click on *MCC / Rezero all motors*. Follow instructions to rezero Syringe Drives, Z, V, X and Y motors.

The X and Y motors will make a loud rattling noise when they are rezeroed. This noise is caused by the motors missing steps. This will not harm the system in any way. When the loud noise starts it can be cut short by pressing the red Stop Button (or by clicking on the red Stop Button on the screen).

If this rezeroing routine is not correctly carried out, mechanical errors may occur (e.g. the microtip may be damaged, and the gas-tight syringes may be broken). However, it need only be carried out during the initial setup, or if there seems to be an error with the motor positions. Normally the motor positions are saved to disk after use of the system, and rezeroing is not necessary.

## Adjusting the Alignment of the Plate Loader using Software

The alignment of the arm of the Plate Loader with respect to the table can be adjusted using software as follows. This adjustment is distinct from the alignment of the microtip. It is intended that the adjustment of the arm provides a permanent change, whereas the user is encouraged to adjust the alignment of the microtip on a day-to-day basis.

1. Place the stainless steel alignment frame in the top left corner of the table.
2. Rezero the Plate Loader (see above).
3. Start the program *Front Panel*
4. Click *view / debug*
5. Click *Plate Loader / Align Arm*, and follow instructions. Clicking on *Save* will apply the adjustment and save it to the registry.

## USE AND MAINTENANCE OF THE HARDWARE

### Installing Microtips

Simply screw the colored end-fittings into the ports on the bottom of the lower valves, following the color-coding. The 2-bore Microtips are generally used for screening experiments, while the 5-bore Microtips are generally for optimization experiments. (5-bore Microtips are occasionally used for large screening experiments too.)

Take a little trouble when installing Microtips. You will find that each tube has two “natural” positions (the tube runs back and then to the side, or, alternatively, to the side and then back). One of these natural positions allows the tube to clear the Plate Loader, whereas the other position causes the tube to collide with the Plate Loader. Choose the former.

### Use of Liquid Handling System Including Valve Positions

#### Refilling 100µl Gas-Tight Syringes with Water

The 100µl syringes contain only degassed pure water. This means that there is no need to flush them when the stock solutions are changed. Degassing is very helpful in reducing bubbles.

When a motorized syringe is almost empty, the software will detect that it is necessary to refill the syringe with water. Follow instructions, including turning the upper valve to the refill position ( $\perp$ ) as indicated.

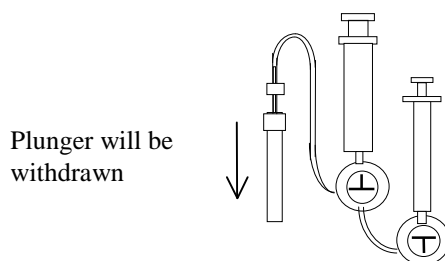

The refill valve position ( $\perp$ ) is also used for rezeroing motors and debubbling.

#### Debubbling

It is essential that all tubing on channels 1 – 5 is completely filled with water, and that there are no air bubbles. Any air bubbles will cause significant inaccuracy in dispensing. The motorized syringes contain only degassed pure water. (If you do not use degassed water you may have to debubble up to twice a day.)

To debubble, select the *debubble* option (under either *syringes* or *execute* on the main menu) and follow instructions.

### Flushing Tubing between Valves

It will occasionally be necessary to remove bubbles or to flush debris out of the short length of tubing between the upper and lower valves. Turn the upper valve to the flush position (┆) and the lower valve to the fill position (⊥). Flush water from the ground glass syringe to the disposable syringe. This prevents debris from being flushed out of the microtip, which could cause blockages.

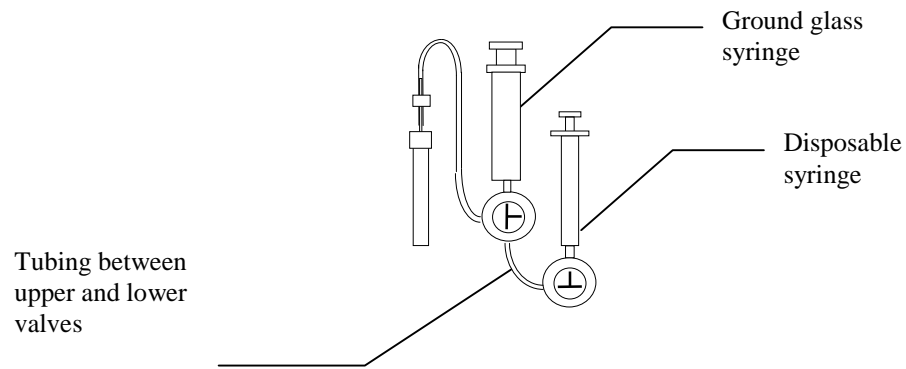

### Filling Microtip with Solution

Software will tell you when to fill the Microtip with stock solution or water. Follow instructions, including turning the lower valve to the flush position (┆).

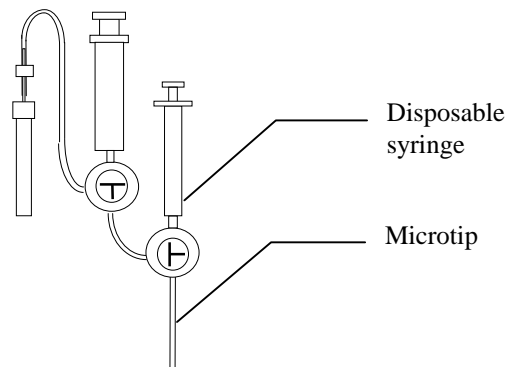

## Dispensing Experiments

Follow instructions and turn all valves to the dispense position (T) as shown:

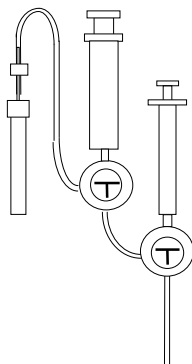

## Flushing Microtip after Use

The Microtip should be thoroughly flushed after each session. Place a 1ml syringe containing distilled water in each valve in the lower row, turn the valve, and press in the plunger firmly. Repeat this three times. Finish by passing air through the Microtip and disconnecting. Store it coiled up and flat to avoid bending of the tip.

## Protein Coatings of Microtip

Certain proteins may have a tendency to coat the inside of a microtip. This may cause the air bubble (that is used to separate the protein sample from the water in the microtip) to become stuck or to break up. Tips that are coated with protein can be cleaned by flushing first with 1 M NaOH, then with buffer solution to get rid of the alkali. If this procedure does not work, try conc. HCl mixed with an equal volume of methanol (again followed with buffer to remove the acid).

## Blockages

Keep syringes in all valves when not in use to avoid the ingress of dust. Never allow precipitant to come into contact with tubing that has previously contained protein unless it has been cleaned using alkali or acid – see above. Filter all solutions using a 0.45  $\mu\text{m}$  filter or equivalent, and refilter any solutions that become cloudy or contain debris.

## Unblocking Microtips

1. First try forcing the debris out of the tip with high pressure. This method is only possible when the Microtip is full of liquid. Fill a 100  $\mu\text{l}$  gas-tight syringe with water. Attach a pointed 0.7 mm needle to it (this is the type of needle that spare syringes come with). Push this into the blocked bore of the Microtip at the End-Fitting. Press in the plunger of the syringe. Up to 100 atmospheres can be generated by this method.

If this does not work or if the Microtip contains air try the following:

2. Fill a 1 ml. disposable plastic syringe with *water* to the 0.5 ml mark, and push it into the spare Luer female connector, excluding as much air as possible.

3. Screw the Luer female into the spare valve, and screw the end-fitting of the blocked bore of the Microtip into the opposite side of the valve. (Alternatively, push the appropriate size of disposable needle straight into the bore of the microtip at the end-fitting.)
4. Place a few milliliters of approximately 1 M NaOH solution in a beaker, and heat until it boils.
5. Place the blocked tip in the boiling NaOH solution, and withdraw the plunger of the syringe to the 1 ml mark. Hold the tip and syringe in this position for approximately 30 seconds.
6. Remove the Microtip from the solution and try to remove the blockage by pushing in the syringe plunger. Repeat steps 5 and 6 until the blockage is removed.

It seems to be important that the NaOH solution is actually boiling, since this reduces the surface tension of the solution to zero. This allows the liquid to be sucked into the blocked bore more easily.

Sometimes boiling water can be used instead of boiling NaOH. In this case the heat softens the microtip enough to allow the blockage to pass out of it.

## Chemical Inertness

All surfaces that come into contact with solutions are chemically inert fluorocarbon polymers including FEP and PTFE. Only water comes into contact with the stainless steel needles of the gas-tight syringes.

## Tubing Connections

The needles of the gas-tight syringes are connected to the FEP tubing by enlarging the bore at the end of the tubing and pressing onto the needle. If any syringes need to be replaced retain the special needles.

All other connections are made using gripper fittings. These are fitted as follows:

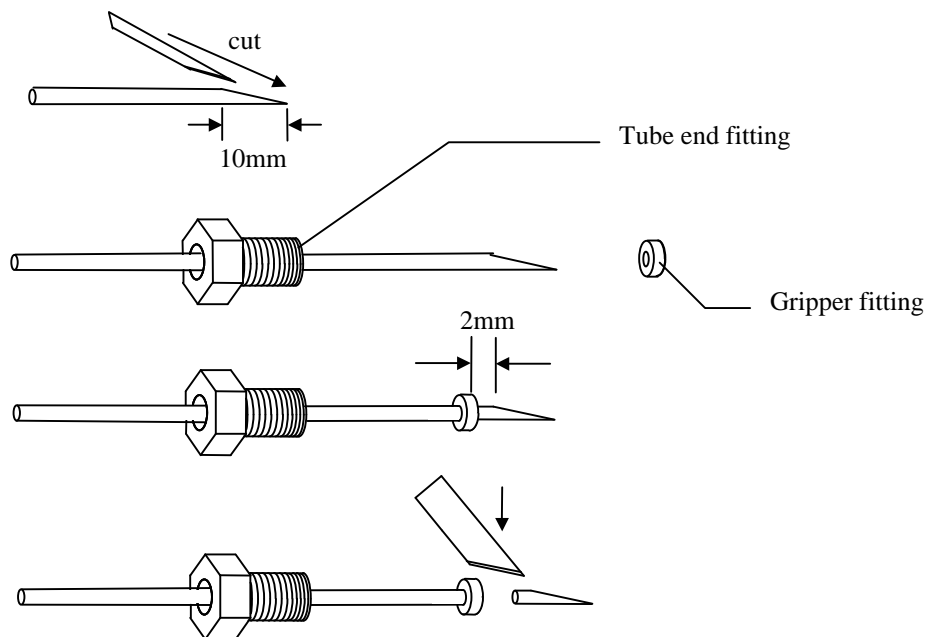

1. Taper the tubing with a scalpel by cutting it at an acute angle.

2. Pass the end through the tube end fitting and feed into the stainless steel side of the gripper fitting.
3. Grip the end of the tube with a pair of pliers and pull the tube through the gripper fitting beyond the tapered portion of the tube onto its full diameter, and rotate twice to grip the tube.
4. Pull the tube end fitting down to meet the gripper.
5. Trim the tube flush to the Teflon face of the gripper with a scalpel.

## **Lubrication of Syringe Drivers and Plate Loader.**

### **Lubrication of Shafts**

No lubrication will be required in the first year. Thereafter, inspect the shafts of the Plate Loader and the Syringe Drivers once a year. If they appear to be dry, lubricate them with one or two drops of differential gear oil for cars - SAE 80W-90 or similar. This will contribute to the smooth running of moving parts, and protect from air-bourn corrosive materials such as are found in laboratories. (All parts are stainless steel or anodized aluminum, which will not generally corrode in the presence of moisture alone.)

### **Lead-screws**

*Lead-screws must not be lubricated with oil, as this may clog up the motors.* Lead-screws are sparingly lubricated by Douglas Instruments with special compound for lubricating plastic. Please contact Douglas Instruments if you feel that your lead-screws need to be lubricated or if they become corroded.

### **Spillages**

If large amounts of liquids are spilt on any of the electric motors, the system should be turned off. Salt, acid or alkali will cause corrosion of motors and stainless parts, and must be washed off with water. Allow the system to dry out before reusing. The motors and their connections are electrically safe since they run at 12 V.

## **XYZV Plate Loader**

### **Jamming**

Bending the lead-screws of the Plate Loader may cause jamming. The lead-screws should be removed and can be replaced or straightened by eye. If this is not the cause of such jamming, misalignment of the linear bearings may be indicated. This is caused by physical shocks to the unit. Please return the unit to Douglas Instruments for refurbishment.

### **Adjustment of XYZV Plate Loader**

The XYZV Plate Loader is adjusted so that it accurately moves to the center of wells on plates. Douglas Instruments performs this adjustment before shipping. If the Plate Loader is subjected to shock or if screws are slackened, it may need to be readjusted. The adjustment can be made in either hardware or software.

If you believe that the Plate Loader is in need of adjustment, please contact Douglas Instruments. Please do not attempt to make adjustments without consulting the company, since there are hidden complications in this procedure.

It is possible, however, to adjust the alignment of an individual microtip using Front Panel, providing the misalignment is less than about 2 mm.

# HARDWARE CONFIGURATION AND CONTROL

## Using Different Syringes with the System

Changing syringes is not normally recommended because the screening and optimization software will both have to be changed. In special cases it may be worth considering. We recommend that you consult Douglas Instruments before embarking on such a project.

## Changing Plates

For a complete list of plates that can be used, consult the PLATES.DAT file in the directory *Global Data*. If the plate that you wish to use is not listed, then see the next section on adding new plate definitions.

### WASP and ASPRUN

\*.XPT files for WASP directly specify the plates to be used on the Plate Loader table. In order to use different plate types, the appropriate PLATE statement in the \*.XPT file must be altered. This is simply a matter of using a text editor to modify the existing file.

The PLATE declaration statements are always near the top of the \*.XPT file, and refer to plates by type name - e.g. Nunc HLA refers to a standard 6x12 Nunc HLA tissue culture plate. For a complete list of plates that can be used, consult the PLATES.DAT file in the directory *Global Data*. If the plate that you wish to use is not listed, then see the next section on adding new plate definitions.

### Pick And Mix

*Pick And Mix* makes it very easy to specify plates. The menu function *Setup/Plate\_Type* provides you with a selection of different plate types drawn directly from the *PLATES.DAT* file in the *Global Data* directory. Different plates may be picked with the mouse. When the .MIX file is saved, so the plate type will be saved with it.

### XSTEP – Changing Plates

Plates can easily be changed in XSTEP simply by selecting *Dispensing Parameters*, then *Crystallization Plate*.

## Adding Further Plates to PLATES.DAT

See manual for Wasprun.exe

## Hardware Configuration Files

The hardware is defined by two files, which must match your particular system. These files are `HARDWARE.CFG` and `HARDWARE.FTH`. `HARDWARE.CFG` is found in the *global data* folder, while `HARDWARE.FTH` is found in the `MCC` folder, and it must be downloaded to the `MCC`. See the instructions for installing software.

Obviously, it is essential that the specifications match the hardware, and that these two files match each other. Please do not make any changes to either of these files. In exceptional circumstances Douglas Instruments may instruct you to make certain changes.

### **HARDWARE.CFG**

The typical contents of `HARDWARE.CFG` are as follows:

```
;    Serial No: XYZV-36  18/09/02

Drive 1 Channel 1 Pitch 314.9600 steps/mm Speed 4.00 mm/s Range 75.00 mm Length 92.00 mm
Drive 2 Channel 2 Pitch 314.9600 steps/mm Speed 4.00 mm/s Range 75.00 mm Length 92.00 mm
Drive 3 Channel 3 Pitch 314.9600 steps/mm Speed 4.00 mm/s Range 75.00 mm Length 92.00 mm
Drive 4 Channel 4 Pitch 314.9600 steps/mm Speed 4.00 mm/s Range 75.00 mm Length 92.00 mm
Drive 5 Channel 5 Pitch 314.9600 steps/mm Speed 4.00 mm/s Range 75.00 mm Length 92.00 mm
Drive 6 Channel 6 Pitch 314.9600 steps/mm Speed 4.00 mm/s Range 75.00 mm Length 92.00 mm

Axis X Channel 9 Pitch -13.3477 steps/mm Speed 70.00 mm/s Range 350.00 mm Length 321.00 mm
Axis Y Channel 10 Pitch 20.0369 steps/mm Speed 55.00 mm/s Range 155.00 mm Length 151.00 mm
Axis Z Channel 11 Pitch 39.4541 steps/mm Speed 30.00 mm/s Range 55.00 mm Length 50.00 mm
Axis V Channel 12 Pitch 39.4155 steps/mm Speed 30.00 mm/s Range 55.00 mm Length 40.00 mm Offset -18.00, 0, 0

END
```

### **HARDWARE.FTH**

The typical contents of `HARDWARE.FTH` are as follows:

```
string serialNumber "XYZV-36"
string hardwareDate "18/09/02"
string userName "Cambridge University"

Oryx DB6.4

.( Hardware settings for ) userName count type cr

( Syringe backlashes in steps )

1 0.533 setCurrent 1 92.0 setLength
2 0.533 setCurrent 2 92.0 setLength
3 0.533 setCurrent 3 92.0 setLength
4 0.533 setCurrent 4 92.0 setLength
5 0.533 setCurrent 5 92.0 setLength
6 0.533 setCurrent 6 92.0 setLength

1 1.0 setPitch 1 4.00 setBacklash
2 1.0 setPitch 2 8.00 setBacklash
3 1.0 setPitch 3 12.00 setBacklash
```

4 1.0 setPitch 4 15.00 setBacklash  
5 1.0 setPitch 5 15.00 setBacklash  
6 1.0 setPitch 6 6.00 setBacklash

( Syringe pitches and speeds )

1 314.9600 setPitch 1 4.00 setSpeed  
2 314.9600 setPitch 2 4.00 setSpeed  
3 314.9600 setPitch 3 4.00 setSpeed  
4 314.9600 setPitch 4 4.00 setSpeed  
5 314.9600 setPitch 5 4.00 setSpeed  
6 314.9600 setPitch 6 4.00 setSpeed

( PlateLoader pitches and speeds )

9 0.533 setCurrent 9 321.0 setLength  
10 0.533 setCurrent 10 151.0 setLength  
11 0.400 setCurrent 11 50.0 setLength  
12 0.400 setCurrent 12 52.0 setLength

9 -13.3477 setPitch 9 70.00 setSpeed  
10 20.0369 setPitch 10 55.00 setSpeed  
11 39.4541 setPitch 11 30.00 setSpeed  
12 39.4155 setPitch 12 30.00 setSpeed

: rezeroX 0 rezeroLS ;  
: rezeroY 1 rezeroLS ;

1 constant BeltDrive?  
-68 IndexPositionX !  
378 IndexPositionY !  
6 accelerationTime !  
768 initialPeriodFactor !  
40 decelerationCount !  
100 decelerationRate !

: findzero 16 0 do rezeroX rezeroY 500 ms loop  
rsdump ;

## Specifications

An up to date list of specifications for all Douglas Instruments' products can be found at  
<http://douglas.co.uk/specs.htm>

## Index of Manual

- Adjusting alignment of Plate Loader, 12
- Adjustment of Plate Loader, 17
- Axes - defining positions, 8
- Blockages, 15
- Bubbles, removing, 13
- Chemical inertness, 16
- Cleaning microtip, 15
- Debubbling, 13
- Degassed water, use of, 13
- Electrical connection, 5
- Filling Microtip with solution, 14
- Flushing Microtip after use, 15
- Flushing tubing between valves, 14
- HARDWARE.CFG, 11, 19
- HARDWARE.FTH, 19
- Installing lead-screws, 10
- Installing Microtips, 13
- Installing the Z and V arms, 10
- Lay-out of the hardware, 4
- Logging motor positions to disk, 5
- Lubrication, 17
- MCC Motion Control Center, 4
- Microtip
  - collisions with Plate Loader, 13
  - installing, 13
  - protein coatings, 15
  - unblocking, 15
- Motors - defining positions, 8
- Performance of Plate Loader - testing, 11
- Phasing lead-screws, 10
- Phasing motors, 8
- Plate Loader
  - adjusting alignment with software, 12
  - testing performance, 11
- Plates
  - adding, 18
  - changing, 18
  - changing, 18
- Plates, adding new designs, 18
- Recording the positions of motors, 5
- Refilling Motorized Syringes with water, 13
- Rezeroing motorized syringes, 5
- Rezeroing Plate Loader, 12
- Software installation, 4
- Specifications, 20
- Speed of Plate Loader - setting, 11
- Spillages, 17
- Syringes
  - debubbling, 13
  - filling with degassed water, 6
  - mounting, 6
- Syringes, changing, 18
- Testing performance of Plate Loader, 11
- Tubing connections, 16
- Unblocking Microtips, 15

July 2001

## SOFTWARE INSTALLATION INSTRUCTIONS

### Installing the New Software on the Host PC

Please follow these steps to install the software on the host PC:

1. Put the CD into the drive of the host PC, and wait for the **Setup** window to appear.
2. Click on each button in turn, starting at the top, and follow instructions.
3. When you install the **Utilities**, select your system from the list to install your hardware files.
4. If you select IMPAX hardware files (as opposed to Oryx) you will not be able to install the last option, **Pick and Mix**, because this is not recommended for IMPAX.

### Upgrading the MCC Software

1. Switch on the “Motion Control System” and run the program *MCCTerminal*. (An easy way to start this program is to run *Front Panel*.)
2. Click **File | Upgrade Flash Firmware**
3. Navigate to `c:\Program Files\Douglas Instruments\MCC\Upgrade.ugl`
4. Click on **Open**. This will select several files
5. Click on **Upgrade Now**
6. A message will appear describing the upgrade. Click on OK
7. The MCC will now be upgraded by transferring files to it. This will take about 1 minute.
8. A message will appear asking you to reboot the MCC. Switch the MCC off and on and click OK
9. Close and restart *MCCTerminal* (and *Front Panel* if this was started.)

For more information, a PC monitor and keyboard can be attached to the MCC, which has a regular PC in it.

### Configuring System

The system should now be configured by clicking on

*Start | Programs | Douglas Instruments | Front Panel*

or run `c:\Program Files\Douglas Instruments\Front Panel\Front Panel.exe`

The system is now ready for use. Refer to the user cards.